



t +1 (416) 744-7545

f +1 (416) 744-9390

w www.packsmartinc.com

e info@packsmartinc.com

MVC Series—Vacuum Transport

The Pack-Smart transport vacuum conveyor is ideal for all custom tipping, folding and gluing applications. Fully adjustable and easy integration make it the ideal compliment to any folder gluer, converting or web finishing line for the graphic arts and packaging industries; and with an industry best 500 FPM, Pack-Smart's vacuum conveyor is an essential part to any packing and printing assembly line.

MVC Standard Features

- Variable Vector drive
- Fully expandable and adjustable
- Selectable vacuum zones
- Variable Vacuum
- Ergonomic modular design
- Operator friendly touch panel
- Universal mounting rails for easy integration of 3rd party equipment
- Heavy duty construction

Process Options

- Gluing and Affixing
- Duplex imaging & Drying
- Scoring & Slitting
- Re-moist Glue application
- Mag Stripping
- Signature Tipping
- Window affixing
- Product assembly
- Label application
- RFID systems

Available Widths: 12" 20" 30" 44" 54"

Power Requirements:

220/400/600 VAC

40 AMPS

1 Phase

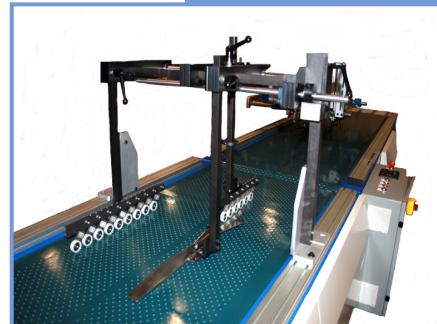
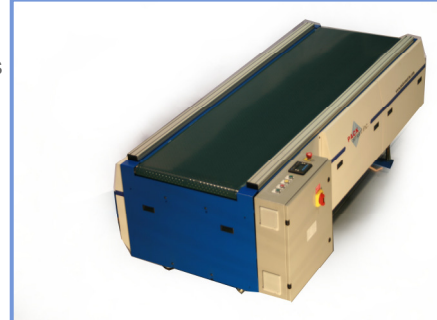



t +1 (416) 744-7545

f +1 (416) 744-9390

w www.packsmartinc.com

e info@packsmartinc.com

MVC Series—Vacuum Transport

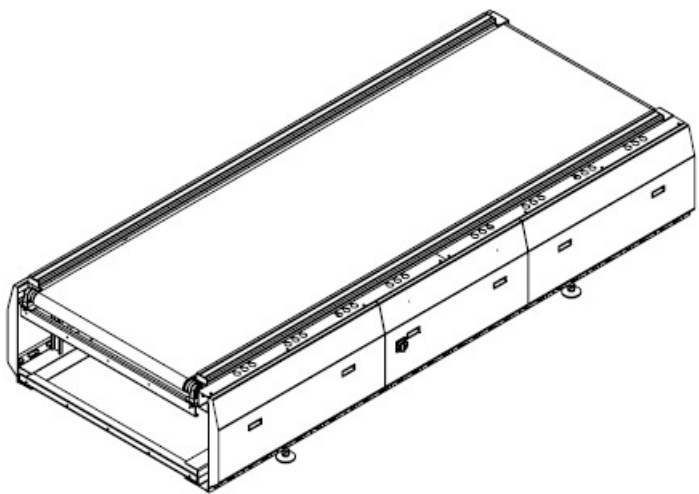

A) 38
B) 49
C) 76

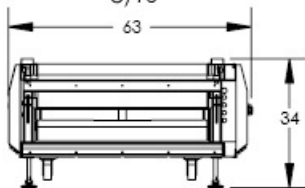

A) 34
B) 34
C) 34

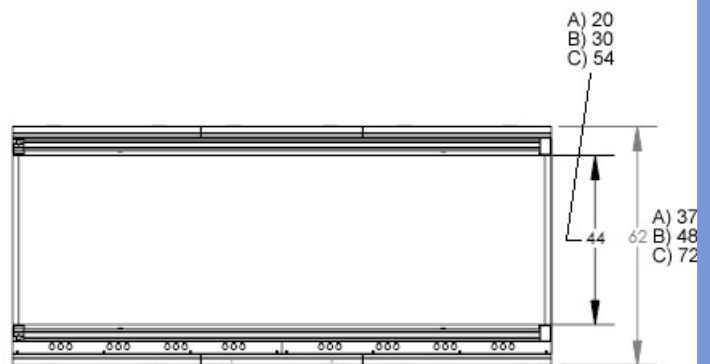

A) 37
B) 48
C) 72

A) 147
B) 140
C) 147

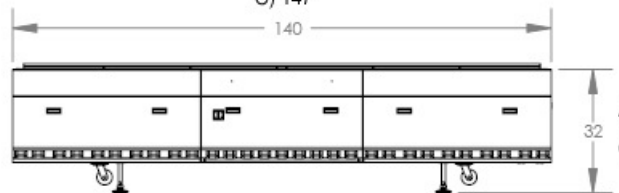

A) 32
B) 32
C) 32

Other Available Sizes:

- A) VC-20 / 20" X 147"
- B) VC-30 / 30" X 140"
- C) VC-54 / 54" X 147"

Dimensions displayed in inches

	PACK-SMART INC. PACKAGING & PRINTING MACHINERY www.packsmartinc.com
	1-118 MILVAN DRIVE, TORONTO, ONTARIO M9L 1Z9 CANADA TEL: 416-744-7545 FAX: 416-744-9390
DWG NAME 44"x140" VACUUM CONVEYOR	
DWG NO. VC-44-140-02	